

Programming & Operating Instruction Manual for Electric Actuators ERQT 0815/0830/1530/1560 with *i*-CON1

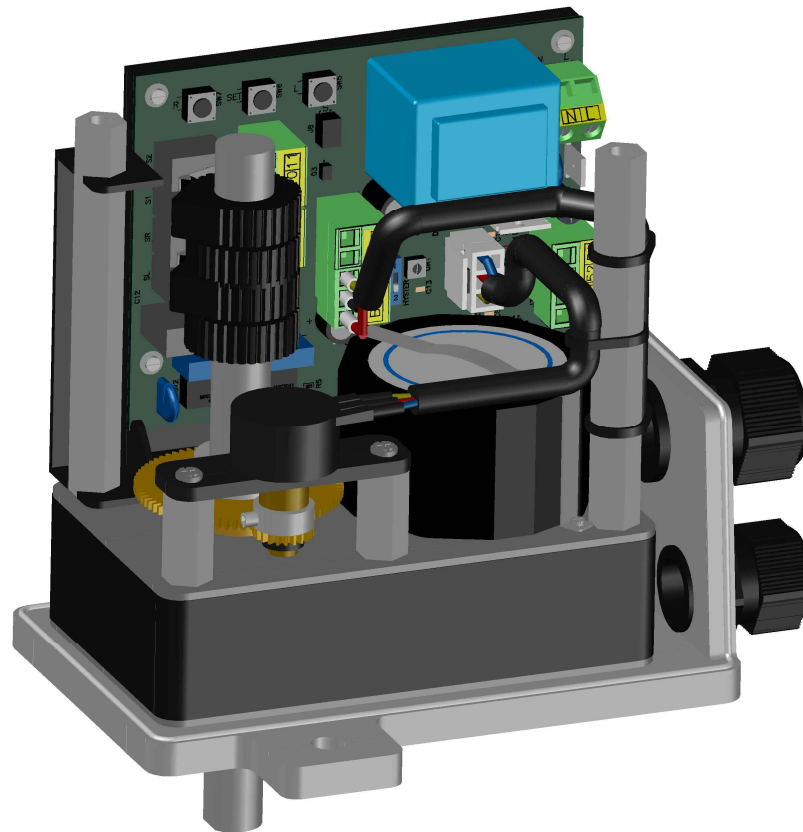

Table of Contents

Liability Statement.....	1
Introduction.....	2
<i>i</i> -CON1 Component Layout.....	3
Wiring of <i>i</i> -CON1.....	5
General Instructions.....	7
Adjusting the limit positions.....	8
Programming <i>i</i> -CON1.....	12
LED - Indicators for <i>i</i> -CON1 Controller.....	16

Liability Statement

Peregrine Electric Actuators are designed for industrial applications only.

Peregrine Electric Actuators are thoroughly tested in factory prior to despatch. However, the final operational test as part of an overall system must be performed by qualified technical staff.

Peregrine Technologies Pvt. Ltd. does not assume any liability for defects of fabrication or any damage or consequential damages resulting from it, in case of inappropriate use, insufficient testing of the actuator as part of an overall system, or if deficiencies have been detected during the initial or further tests and the unit has not been put out of service immediately.

Particular care should be taken to avoid personal injury or damage to property when operating Peregrine Electric Actuators.

The warranty is void in case of non-observance of the operating instructions or inappropriate handling.

These operating instruments may neither be copied, photocopied, reproduced, translated nor be converted into any electronically or mechanically readable format, whether in full or parts thereof, without the prior written consent of Peregrine Technologies Pvt. Ltd.

The present operating instructions are subject to change without notice.

Introduction

1. Peregrine make series *i*-CON, specifically *i*-CON1, microprocessor based (0)4-20mA signal interface are used for control and modulation of Peregrine Electric Actuators, Models ERQT 0815/0830/1530/1560.
2. The *i*-CON1 interface, can be installed and integrated within the actuator housing.
3. The *i*-CON1 interface, compares the input (0)4-20mA signal with the current position of the actuator; should there be a difference between the position specified by the input signal and that of the actuator, then the actuator is operated and moved to the position defined by the input set point signal (0)4-20mA.
4. The *i*-CON1 signal interface also provides by default (0)4-20mA feedback signal, proportionate to the actual position of the actuator.
5. The *i*-CON1 signal interface also allows the user to program individually the 4mA or the "ZERO" point and also the 20mA or "SPAN" point anywhere within the allowable rotation of the actuator. The user can also reverse the direction of rotation of the actuator, i.e. clockwise rotation with increasing signal to anticlockwise rotation with increasing signal; at the flick of a button.

i-CON1, Component Layout

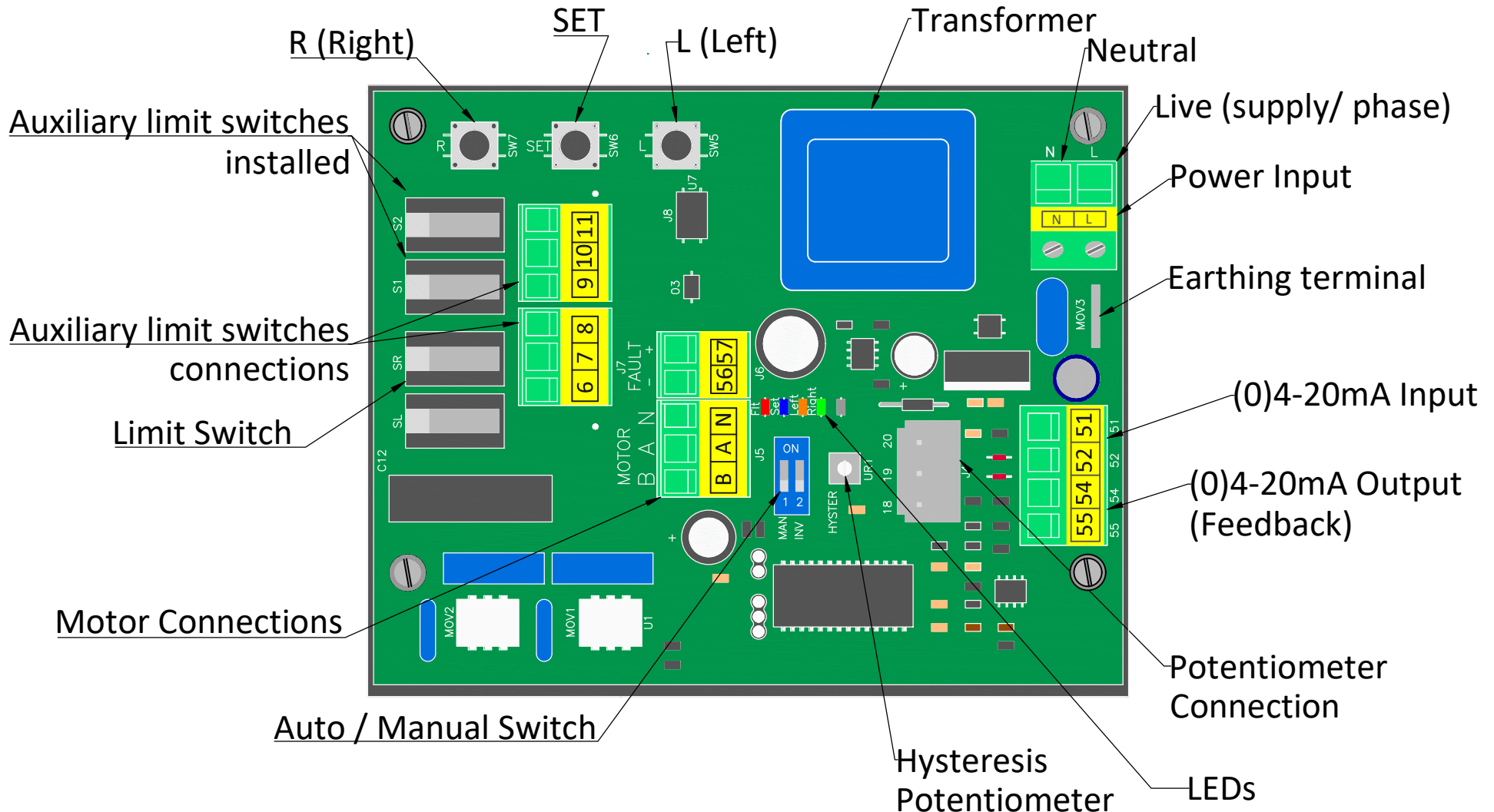



Fig. 1

Precautions while making connections.

The following care must be taken

1. Polarity of supply cable should be verified before connection.
2. Please ensure that, shielded / screened connectors of minimum cross section of 0.5 mm^2 and to a maximum length of 1000 meters is used to carry the (0)4-20mA signal.
3. Make sure that one end of the screening or shielding is connected to the earthing terminal on the *i*-CON1 PCB ().
4. Do not attempt to modify the internal wiring of the actuator.

Wiring of i-CON1.

1. Please refer to the wiring diagram provided inside the actuator cover, before making connections.
2. The wiring diagram mentioned above has been recreated below;

i-CON1 Terminal Connection Details.

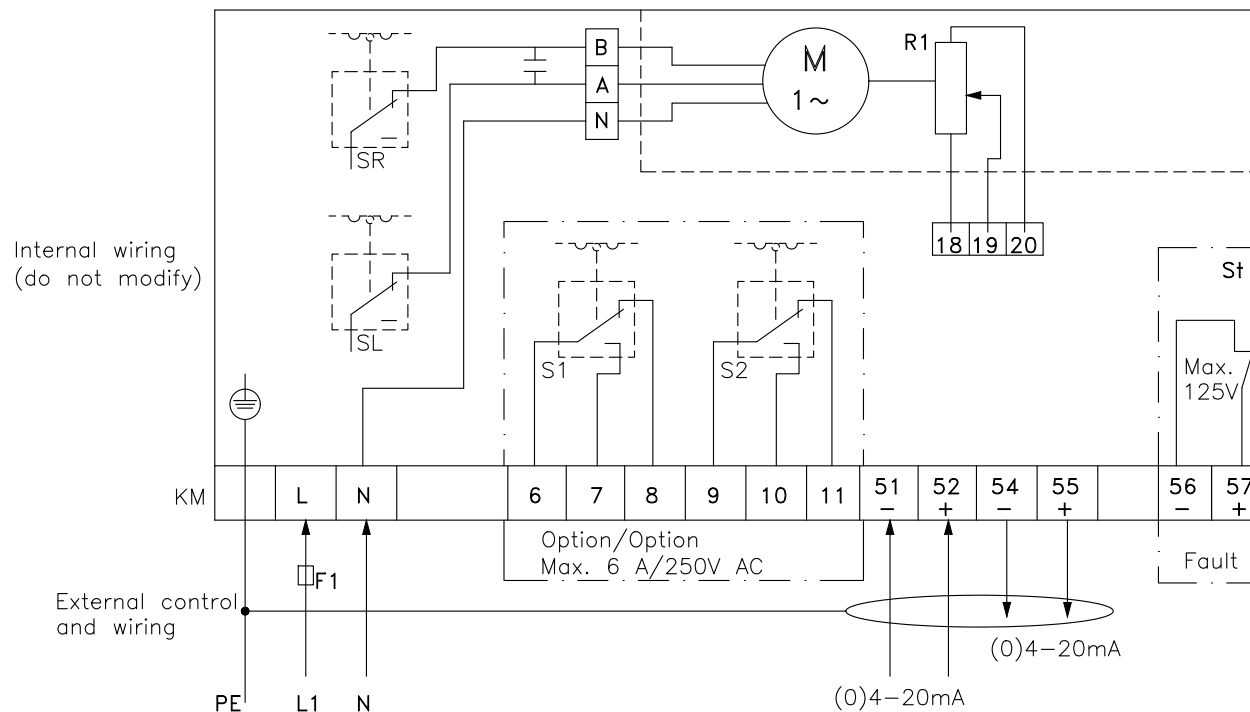

Fig. 2

Terminology

<i>i</i> -CON1	Microprocessor based programmable (0)4-20mA signal interface
KM	Terminal strip for <i>i</i> -CON1, (0)4-20mA signal interface
SL	Position limit switch, CCW rotation
SR	Position limit switch, CW rotation
S1	1. Auxiliary limit switch (option)*
S2	2. Auxiliary limit switch (option)**
R1	Potentiometer for reading actual position of Actuator shaft
St	Fault message
L	Phase
N	Neutral
B A N 18/19/20 } }	Preconnected by Manufacturer; do not attempt to modify

Please make necessary connections, as per the wiring diagram provided in Fig. 2 on page no. 5

Notes.

- * Potential free, change over output of auxiliary limit switch S1, can be obtained from terminals "6","7" and "8", refer Fig. 2
- ** Potential free, change over output of auxiliary limit switch S2, can be obtained from terminals "9","10" and "11", refer Fig. 2

General instructions

- * All adjustments in *i*-CON1 (0)4-20mA signal interface are made via following keys;
'L' (LEFT) key.
'SET' key.
'R' (RIGHT) key.
- * Four LEDs display all the programming steps; details as hereunder-also refer to table on page no.16,
 - Blue LED indicates that *i*-CON1 / Actuator is in '**AUTO**' mode.
 - Red LED indicates absence of signal [4-20mA] or break in conductor carrying the signal.
 - Green LED indicates Actuator shaft rotation in CW direction or '**RIGHT**' (R) key has been pressed.
 - Orange LED indicates Actuator shaft rotation in CCW direction or '**LEFT**' (L) key has been pressed.
- * Set up possible without control signal [(0)4-20mA input; standard presets to be selected].
- * ZERO and SPAN positions can be programmed anywhere, within the operating range of the actuators.
- * Both ZERO and SPAN positions should differ by atleast 20% of maximum span or range available.
- * Programming set point, feedback etc. has to be carried out in '**MANUAL**' mode.

Adjusting the limit positions

1. Make the necessary electrical connections as shown here below, on the terminals provided on the PCB. Ensure every connection is **secure & tight**.
2. Turn on the power supply.

Fig. 3

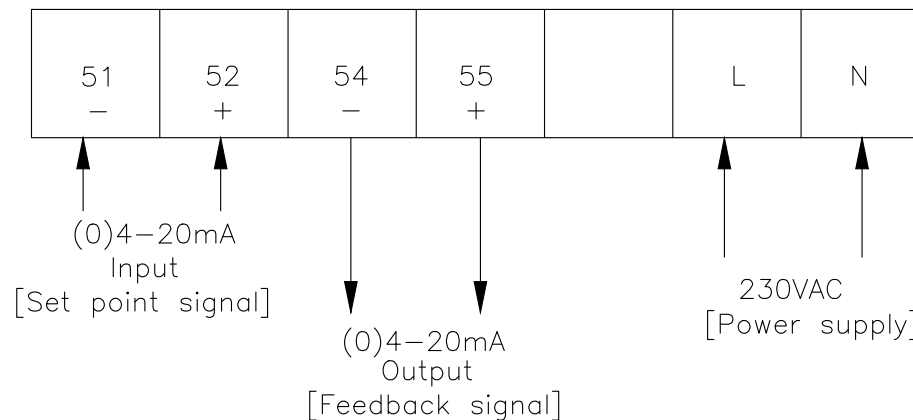

3. Move the **Auto/Manual** switch to '**MANUAL**' mode. Refer to Fig. 4
4. On keeping **Left** key (marked **L**) pressed, Actuator shaft starts turning **LEFT** and the orange (■) LED glows (on seeing from top); Actuator shaft moves CCW. When required position is reached release the Left key.

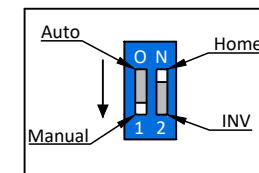

Fig. 4



5. At this position adjust the lower cam (in the CCW direction as shown in Fig. 5) such that Lower switch SL clicks.

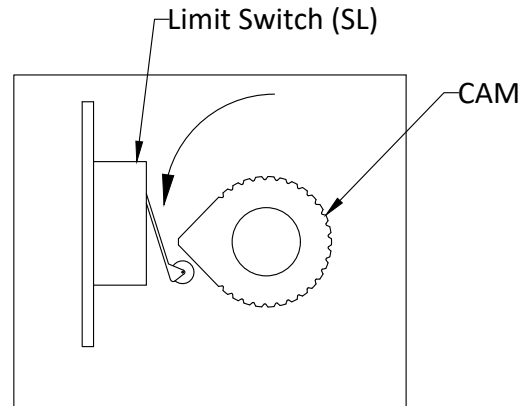

Fig. 5

Rotate cam(L) in this direction
for setting LEFT limit switch.

6. Check whether setting is correct; for this rotate the Actuator shaft in CW direction using 'RIGHT' (R) key. Then using 'LEFT' (L) key approach the set limit and see whether SL clicks at correct position or not.

7. Now keeping RIGHT key (**R**) pressed, the Actuator shaft starts turning right and green (■) LED glows (on seeing from top); Actuator shaft moves CW. When desired position is reached, release the '**RIGHT**' (**R**) key.



8. At this position adjust the upper cam (in the CW direction as shown in Fig. 6) such that upper switch SR clicks.

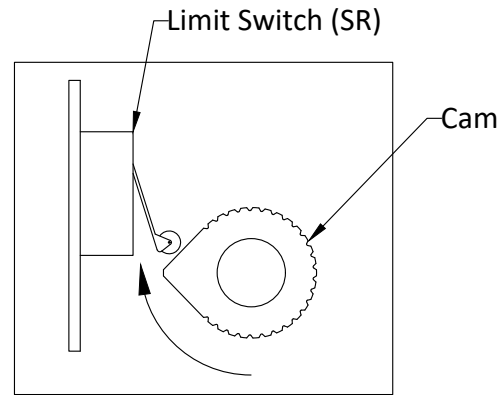

Fig. 6

Rotate cam(R) in this direction
for setting RIGHT limit switch.

9. Check the setting by rotating the Actuator shaft in CCW direction using '**LEFT**' (**L**) key. Now using '**RIGHT**' (**R**) key approach the set limit and see whether SR clicks at correct position or not.

10. This completes, setting of stop positions (limit switches) and potentiometer- which has a 'slip clutch' mechanism, that enables it to automatically set itself up. We however advise you to 'approach' both the end limits a couple of times to ensure proper setting up of the potentiometer.

Important Notes

- * Before making electrical connections, ensure that all the electrical supply as well as signals are switched OFF.
- * Switch SL limits the rotation of Actuator shaft in CCW direction. When SL is actuated (i.e. clicks) supply to the motor is stopped and Actuator shaft stops rotating in CCW direction.
- * Switch SR limits the rotation of Actuator shaft in CW direction. When SR is actuated (i.e. clicks) Actuator shaft stops rotating in CW direction.

Programming *i*-CON1

Programming set-point signal value range

* Setting signal value range to 4-20mA

1. Switch off power to *i*-CON1.
2. Move AUTO / MANUAL switch to '**MANUAL**' mode.
3. Keeping '**LEFT**' (L) key pressed, switch on power to *i*-CON1.
4. Press '**SET**' key within 3 seconds of powering up *i*-CON1.
5. Blue LED blinks thrice ■■■, indicating acceptance of signal range. ##
6. *i*-CON1 is now ready to operate / modulate the actuator between 4mA to 20mA.

* Changing signal value range to 0-20mA from 4-20mA

1. Switch off power to *i*-CON1.
2. Move AUTO / MANUAL switch to '**MANUAL**' mode.
3. Keeping '**RIGHT**' (R) key pressed, switch on power to *i*-CON1.
4. Press '**SET**' key within 3 seconds of powering up *i*-CON1.
5. Blue LED blinks thrice ■■■, indicating acceptance of signal range. ##
6. *i*-CON1 is now ready to operate / modulate the actuator between 0mA to 20mA.

Before start of programming, setting up of stop positions i.e. limit switches and potentiometer should be completed.

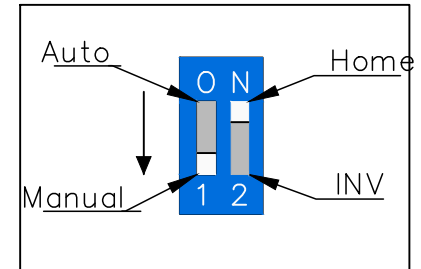

Fig. 7

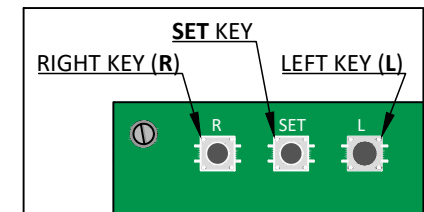

Fig. 8

Notes.

The default / factory setting of signal value range is 4-20mA.

If Blue LED does not blink, then repeat steps 1 to 4.

Indicators

The following indications apply, while Actuator is in '**AUTO**' mode.

- Red LED glows to indicate faulty operation or absence of 4-20mA signal.
- Blue LED glows to indicate that power is "ON" or Actuator is in operation.
- Green LED glows to indicate CW rotation of Actuator shaft.
- Orange LED glows to indicate CCW rotation of Actuator shaft.

Operating Controls

1. 'AUTO / MANUAL' Switch: Used for switching between Auto and Manual mode.
2. 'HOME / INV' Switch: When switch is in '**HOME**' position, then (0)4mA is assigned to Left-hand end of travel (ZERO position) and 20mA is assigned to right-hand end of travel (SPAN position). The Actuator is set to rotate in the CW direction with increasing signal.

When/if Switch is moved to '**INV**' position, (0)4mA is assigned to right-hand end of travel and 20mA is assigned to left-hand end of travel; i.e. the controller *i*-CON1 reverses the ZERO and SPAN positions set when switch was in '**HOME**' position. The Actuator is set to rotate in the CCW direction with increasing signal.

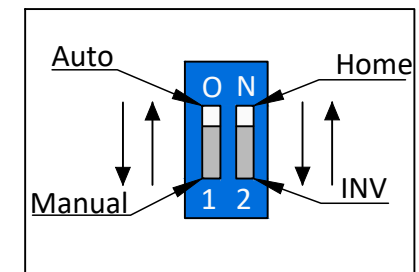



Fig. 9

* Programming Left-hand end of travel

1. Slide Auto / Manual switch to '**Manual**' mode.
2. Go to Left-hand end of travel (0° position) using '**LEFT**' (L) key, after SL switch clicks, press '**RIGHT**' (R) key for some time so that position is brought inside the limit.
3. Press '**SET**' key; blue LED flashes =  =.
4. Then press '**LEFT**' (L) key within 3 seconds.

* Programming Right-hand end of travel

1. Go to Right-hand end of travel (90° position) using '**RIGHT**' (R) key. after SR switch clicks, press '**LEFT**' (L) key for some time so that position is brought inside the limit.
2. Press '**SET**' key; blue LED flashes =  =.
3. Then press '**RIGHT**' (R) key within 3 seconds.

- * Now slide the HOME / INV switch to '**HOME**' or '**INV**' position depending on which side you wish to configure or assign (0)4mA / 20mA; i.e. left- hand or right-hand end of travel respectively.

- * To conclude programming, slide the **Auto / Manual** switch to '**AUTO**' mode; blue LED starts glowing ■ . The controller *i*-CON1 / Actuator now follows the control signal i.e. (0)4-20mA signal.
- * If Red LED glows, while in '**AUTO**' mode and input signal range 4-20mA has been selected (Refer page no.12), then kindly investigate input and polarity of signal to terminals "51" and "52" using suitable instrument / Multimeter. Also check if screws of terminals "51" and "52" are tight enough and are holding the signal cables securely.
- * Hysteresis or sensitivity can be set via the onboard trimming pot (); $\pm 20\%$ adjustment of hysteresis (dead band) is possible.

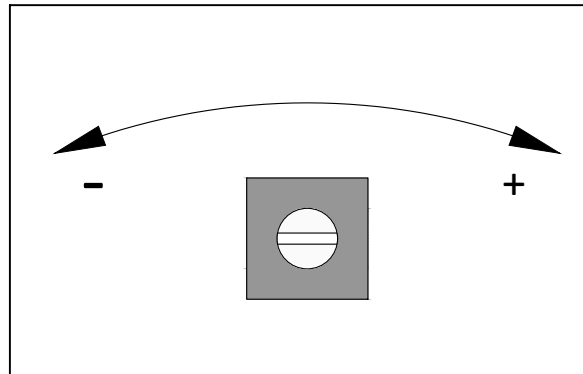

Fig. 10

* LED - Indicators for *i*-CON1 controller

Mode	I/P Key pressed or Set value	LED			
		Orange ■	Green ■	Blue ■	Red ■
Manual	None				
Manual	Right Key (CW Rotation)		ON		
Manual	Left Key (CCW Rotation)	ON			
Auto	Set value Right		ON	ON	
Auto	Set value Left	ON		ON	
Auto	Signal below 4mA /disconnected			ON	ON
Auto	Set value position achieved			ON	
Faulty Programming				ON	ON



PEREGRINE TECHNOLOGIES PVT. LTD.

Unit 138, Building 1,
New Sonal Link Industrial Estate,
Link Road, Malad (West),
Mumbai 400 064, India.

☎ : +91 8879273828 / +91 8291273828 / +91 22 66924767

✉ : sales@peregrinetechnologies.co.in

✉ : postbox@peregrinetechnologies.co.in

www.peregrinetechnologies.co.in