

Operating Instruction Manual for Electric Actuators ERQT 0815/0830/1530/1560

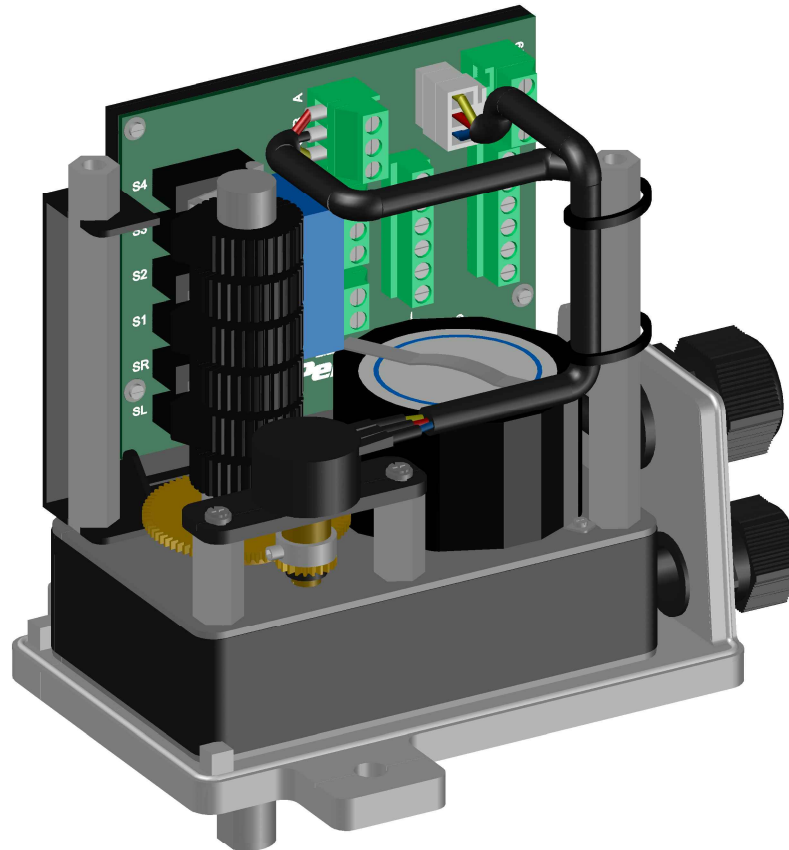

Table of Contents

Valid for Electric Actuators ERQT 0815/0830/1530/1560

Liability Statement.....	1
Safety / Installation Instructions.....	2
Description.....	5
PCB & Components Layout.....	6
Electric Connection.....	7
Self-arresting plastic control cam.....	11
Potentiometer (Option).....	12

Liability Statement

Peregrine Electric Actuators are designed for industrial applications only.

Peregrine Electric Actuators are thoroughly tested in factory prior to despatch. However, the final operational test as part of an overall system must be performed by qualified technical staff.

Peregrine Technologies Pvt. Ltd. does not assume any liability for defects of fabrication or any damage or consequential damages resulting from it, in case of inappropriate use, insufficient testing of the actuator as part of an overall system, or if deficiencies have been detected during the initial or further tests and the unit has not been put out of service immediately.

Particular care should be taken to avoid personal injury or damage to property when operating Peregrine Electric Actuators.

The warranty is void in case of non-observance of the operating instructions or inappropriate handling.

These operating instruments may neither be copied, photocopied, reproduced, translated nor be converted into any electronically or mechanically readable format, whether in full or parts thereof, without the prior written consent of Peregrine Technologies Pvt. Ltd.

The present operating instructions are subject to change without notice.

Safety & Installation Instructions

General recommendations

- Peregrine Electric Actuators are designed exclusively for industrial application.
- When operating electrical devices certain components are necessarily under live voltage. Work on electrical installations or equipment must only be carried out by expert electricians or duly instructed personnel under the guidance and supervision of an expert electrician in accordance with pertinent rules and regulations.
- Strictly observe all applicable regulations for safety and accident prevention during installation, commissioning and testing work.
- Before starting any work, installation, etc. on the actuator, make sure you did properly disconnect all equipment / installations affected by it.

Instruction for working on Actuators

- Please note, when starting the actuator all attached fittings/ levers/ rod assemblies, etc. start to move with it.
- Check all emergency devices of your equipment/ plant for correct operation.
- After completion of any adjustment work, verify proper functioning of the actuator and all attached fittings/ levers, etc. moved by it.
- Never install or work on a defective actuator.

Installation Instructions

- Check Actuators for any signs of damage prior to installation.
- Remove corrosion protection (if applied for storage purpose) and replace by grease before installation.
- Check imperviousness of cable entries and blind plugs prior to setting into operation.
- Tighten evenly all screws of the cover.
- Do not start operation before properly setting the limit stop switches.
- Protect Actuators from atmospheric exposure (e.g. canopy)
- Protect Actuators from shocks and impacts (e.g. by dropping it)
- Do not fasten ropes, hooks or similar directly to the Actuator.
- Permanent overloading and blocking of the Actuator may damage it.
- Spark quenching condensers may affect the sense of rotation stability of the Actuator and cause damage.
- Use only original Peregrine accessories.

Note when installing couplings

- Do not turn Actuator output shaft by force.
- Output shaft and fittings spindle must be running centered (compensate coupling, if necessary).

Type of Protection

IP65 (Standard), IP66/67 (option)

The following must be strictly observed for all types of Actuators.

1. Cable Entries

- When storing, installing or setting into operation, make sure that all cable entries are always perfectly sealed. Use only cables suitable for the diameters of cable entries.

2. Installation of cover

- Actuators may be set into operation only with properly closed covers and sealed cable entries.
- When mounting the cover make sure O-rings under the screws of the cover and the O-ring inside the Actuator housing, perfectly seal the interface/ joint.
- The facing surface of the cover must not show any signs of damage.
- Tighten the screws of the cover evenly.

3. Housing / cover

- No additional bore holes are permitted in the housing or cover of the Actuator.

Description

Peregrine Electric Actuators are used to operate control and shut-off devices (dampers, valves, cocks, gates, metering pumps, etc.). The Actuator can be mounted in any orientation.

Direct attachment to the control unit is made by means of mounting brackets which are fastened to the Actuator.

A choice of different mounting brackets is available.

The Actuators are equipped with permanent grease lubrication and thus is maintenance-free.

Parallel Operation

If several Actuators are controlled via one common contact each actuator must be fitted with a relay for parallel operation (see wire diagram on page 9).

PCB (BASIC 1) & Component Layout

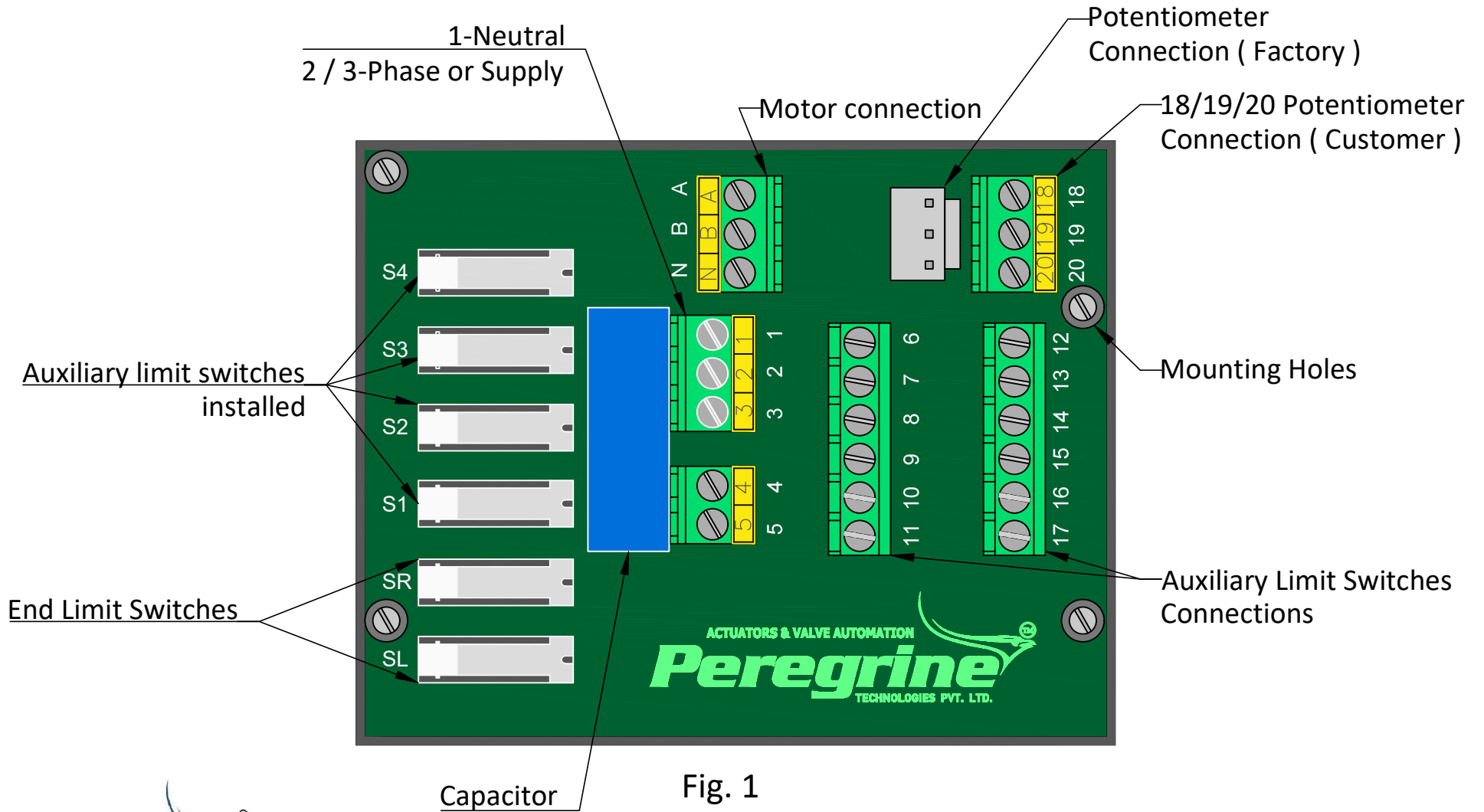

Fig. 1

Electric Connection

Application rules and regulations concerning electric installation and setting into operation must be strictly observed. Regarding connection and setting into operation of explosion-proof electrical equipment; the applicable national regulations for assembling electric installations in hazardous locations must be complied with.

- Check for conformity of type of current, line voltage, and frequency with motor characteristics (see type plate on cover and inside the actuator).
- Use screwed cable glands appropriate for the connection line.
- Do not under-run the minimum bend radius of the wires.
- Make sure to follow the wiring and terminal connection diagram affixed inside the cover.
- For extra-low voltages (e.g. potentiometer) separate wires must be used; if necessary shielded ones.
- All components like switches, potentiometer, relays, etc. are already wired in factory.
- Follow the steps explained under "Determining the sense of rotation" when connecting the Actuator (see page 8).
- Before setting the Actuator into operation adjust the position limit switches (see page 11).
- Grounding must be done properly on the grounding terminal inside the Actuator.

Type of protection IP65 (standard) up to IP67 (optional) are guaranteed only when using appropriate screws. The grounding wire has to be attached to the appropriate screw. The grounding wire has to be attached to the appropriate screw with a ring cable lug.

Determining the sense of rotation for standard 230VAC/110VAC Actuator

Position Switch-off

Based on the internal wiring the following assignments apply to sense of rotation (looking through the Actuator towards the output shaft) and limit stop switches;

1. Applying line voltage to terminals 1 and 2 produces CCW rotation of the output shaft.
The SL switch limits this sense of rotation. If this switch is actuated line voltage is applied to terminal 4.
2. Applying line voltage to terminals 1 and 3 produces CW rotation of the output shaft.
The SR switch limits this sense of rotation. If this switch is actuated line voltage is applied to terminal 5.
3. If the Actuator runs in opposite direction to the control commands, switch external connections between terminal 2 and 3.

The internal wiring must never be changed.

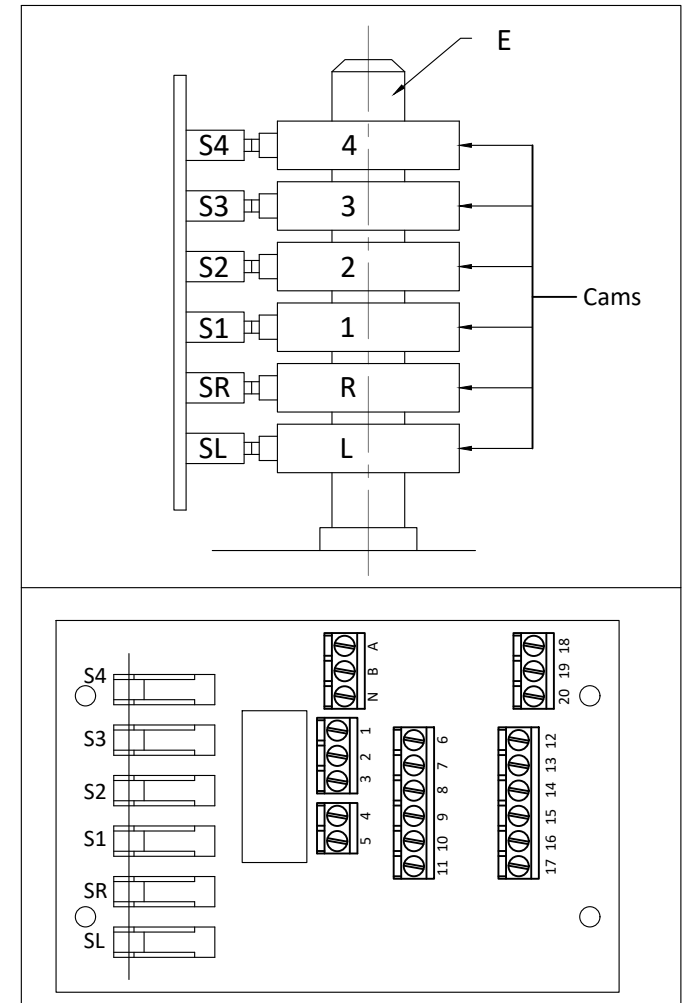

Fig. 2

Wiring & Terminal Connection Details

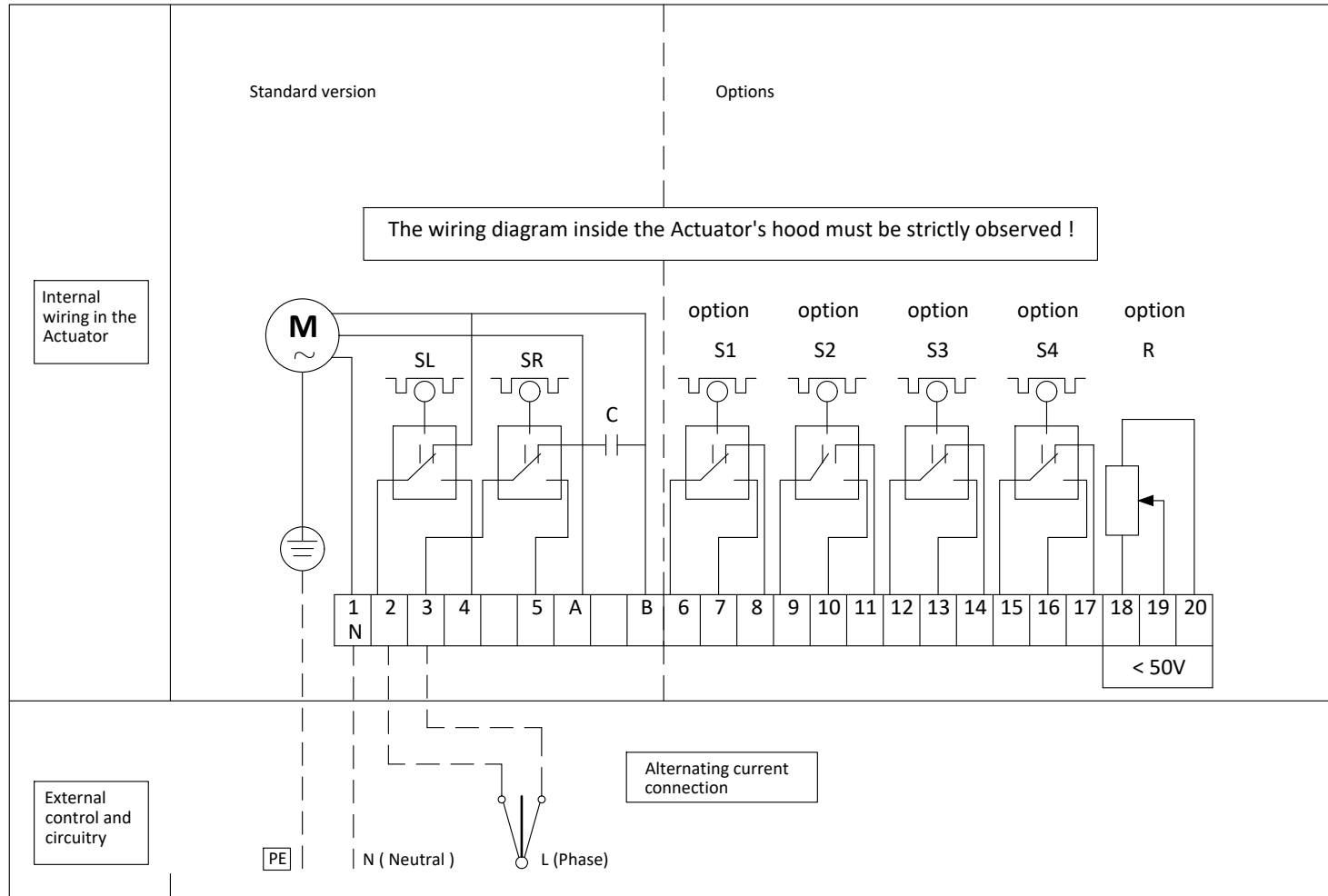

Fig. 3

Wiring Diagram

SL	Limit stop switch, CCW rotation
SR	Limit stop switch, CW rotation
S1	Auxiliary Switch 1*
S2	Auxiliary Switch 2*
S3	Auxiliary Switch 3*
S4	Auxiliary Switch 4*
R	Potentiometer
B A N	Preconnected by Manufacturer; do not attempt to modify
18/19/20	Potentiometer Connection (Customer)

Depending on the particular model, the position limit switches may be arranged differently than indicated in the wiring diagram (Please check the wiring diagram inside the Actuator).

***The auxiliary switches S1-S4 must operate within the same voltage range. A mixture of main voltage and low voltage is not allowed.**

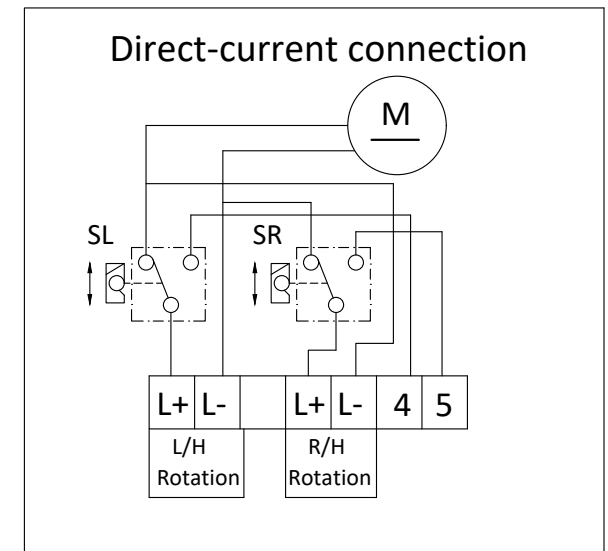

Fig. 4

Self-arresting plastic control cam

Position switches

Control cams can be turned manually and need not to be locked.

1. Apply voltage (see page 8):
Actuator turns in pre-determined direction.
2. When reaching the limit position to be set, disconnect voltage (gear must not seize).
3. Turn control cam L in the sense of rotation of the control camshaft E until the position limit switch SL clicks.
4. Set control cam R for opposite sense of rotation as described in step 1-3.
5. For control purposes activate once again electrically both limit stop positions and readjust, if necessary.
6. For further switches: Proceed as indicated in step 1-5.

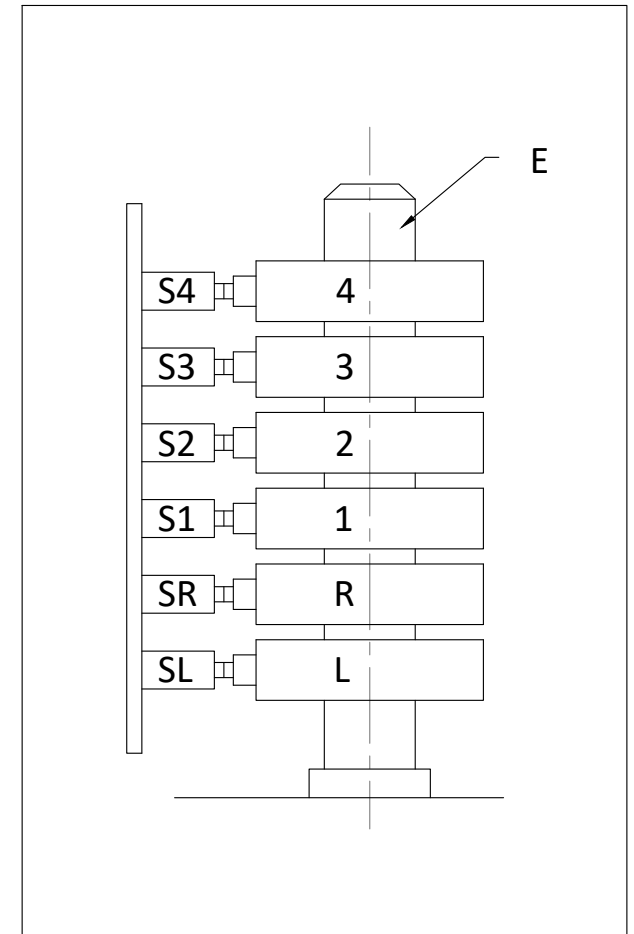

Fig. 5

Potentiometer (Option)

Electrical connection

Wire terminal 18, 19 and 20 according to requirements (voltage = 50V); (see page 9)

Use separate wires, if necessary, shielded ones.

Follow the wiring diagram inside the cover.

Setting:

Set position limit switches first, then adjust the potentiometer **R**.

Approach both limit positions electrically (see page 11).

Consider regulating distance and potentiometer resolution. The regulating distance ordered by customer must not be overrun as permanent overrunning could damage the slip clutch **SC**.

The potentiometer **R** makes automatically a rough adjustment via slip clutch **SC**.

The regulating distance of the valve / fitting is transferred by the slip clutch **SC** to the electric rotation angle of the potentiometer.

Approach again electrically both limit position (see page 11) and re-adjust the potentiometer **R** with slip clutch **SC**.

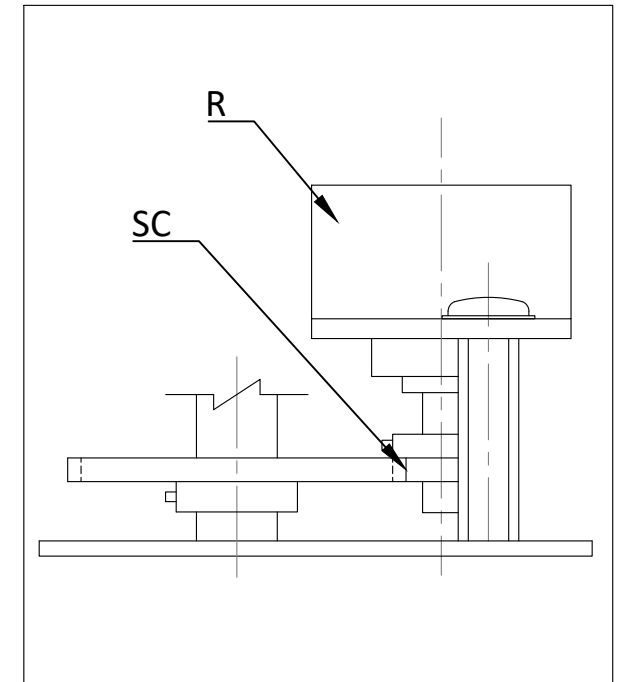

Fig. 6



PEREGRINE TECHNOLOGIES PVT. LTD.

Unit 138, Building 1,
New Sonal Link Industrial Estate,
Link Road, Malad (West),
Mumbai 400 064, India.

☎ : +91 8879273828 / +91 8291273828 / +91 22 66924767

✉ : sales@peregrinetechnologies.co.in

✉ : postbox@peregrinetechnologies.co.in

www.peregrinetechnologies.co.in